

**NOTE:** Do not assemble caster to caster support until last step.

### ASSEMBLY INSTRUCTIONS:

- A) Lay rack frame on side to mount casters (item 1).
- B) Mount caster support (item 8) to corner bracket (item 6) using 5/16 flat head screw (item 3). The second flat head screw secures the caster support to rack bottom lip (item 7) thru tapped hole in caster clamp (item 4). Use one washer (item 5) as spacer. See diagram.
- C) Assemble caster (item 1) to caster support (item 8) last so that flat head screw (item 3) will be partially covered. Secure using 1/4-20 kep nuts (item 2).

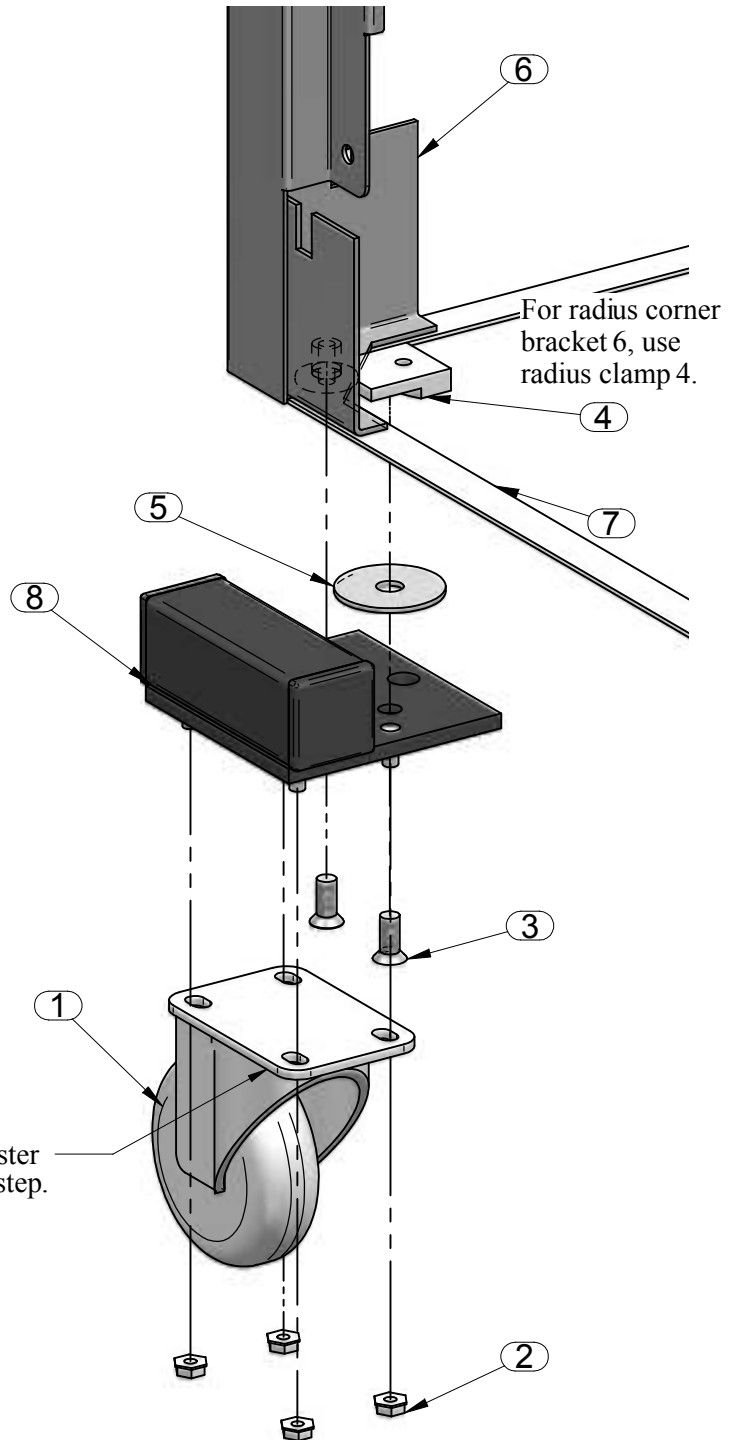

Note: Do not assemble caster to caster support until last step.

PARTS LIST		
ITEM No.	DESCRIPTION	QTY
1	CASTER	2
2	1/4-20 KEP NUT	8
3	5/16-18 X 1.0 FH SCREW	4
4	CASTER CLAMP	2
5	WASHER	2
6	CORNER BRACKET (RACK FRAME)	2
7	RACK BOTTOM (RACK FRAME)	1
8	CASTER SUPPORT	2

#### TOOL BOX



3/8, 7/16" Socket  
Wrench



#3 Phillips  
Screw Driver

