

Note: For 1 unit high cabinet use internal corner brackets typical 4 corners. See step A

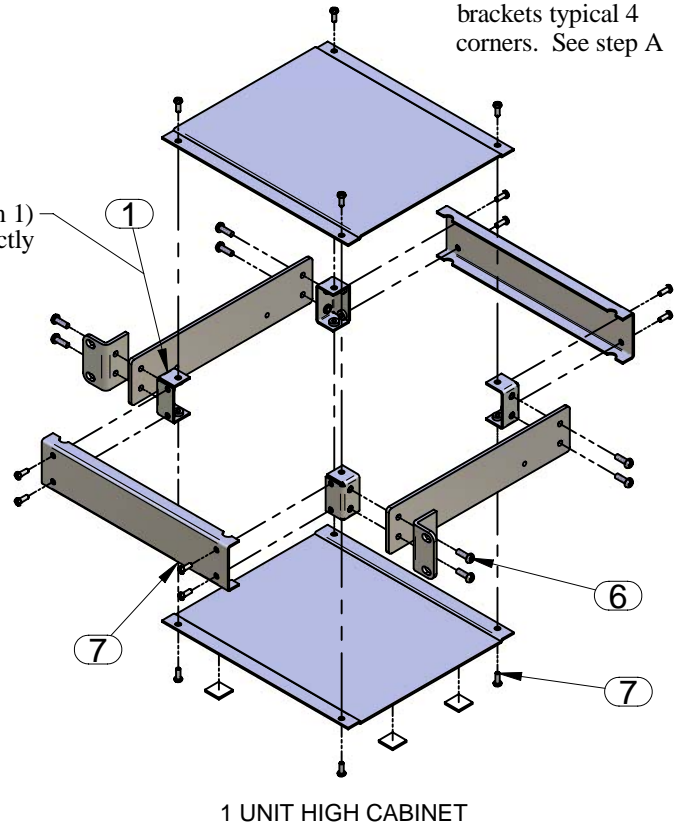
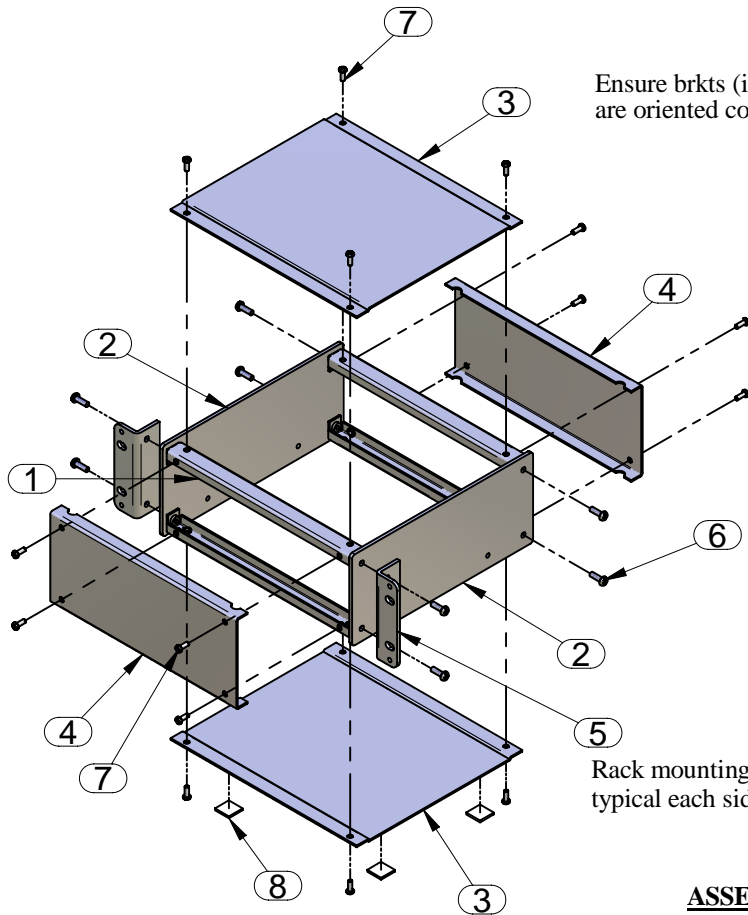

### ASSEMBLY INSTRUCTIONS:

- A) Assemble sides (item 2) to the internal rails (item 1) or internal corner brackets (1 unit high) using 8-32 x 1/2 machine screws (item 6) as shown. Ensure holes on internal rails face out and extra holes on sides are at the bottom.
- B) For rack mounting, install rack mounting brackets (item 5) to sides. Rack mounting brackets also require to install handles (sold separately).
- C) Fasten top and bottom panels (item 3) to the internal rails (item 1) using 6-32 x 1/4 self tapping screws (item 7) as shown.
- D) Fasten front and rear panels (item 4) to the internal rails (item 1) using 6-32 x 1/4 self tapping screws (item 7) as shown.
- E) Install rubber feet (item 8), (self adhesive), in desired location on bottom if required.

PARTS LIST		
ITEM No.	DESCRIPTION	QTY
1	INTERNAL RAILS OR CORNER BRACKETS	4
2	SIDES	2
3	TOP/BOTTOM PANELS	2
4	FRONT/REAR PANELS	2
5	RACKMOUNTING BRACKETS	2
6	8-32 MACHINE SCREWS	8
7	6-32 SELF TAP SCREWS	16
8	RUBBER FEET (SELF ADHESIVE)	4

TOOL BOX



#2 Phillips  
Screw Driver

