

RCHS - SERIES

ASSEMBLY INSTRUCTIONS FOR RCHS KNOCKDOWN CABINET

BUL10297

REV. B

PAGE 1 OF 1

Item #	Description	Qty
1	RCHS K.D. - BOTTOM	1
2	RCHS K.D. - SIDE	2
3	RCHS K.D. - TOP	1
4	RCHS K.D. - PUNCHED COMBO RAILS	4
5	SCREW - 1/4-20 X 1/2 BND HD, PH/SL, BLK	8
6	NUT 1/4-20 KEP ZP	8
7	PLASTIC HANDLE	2

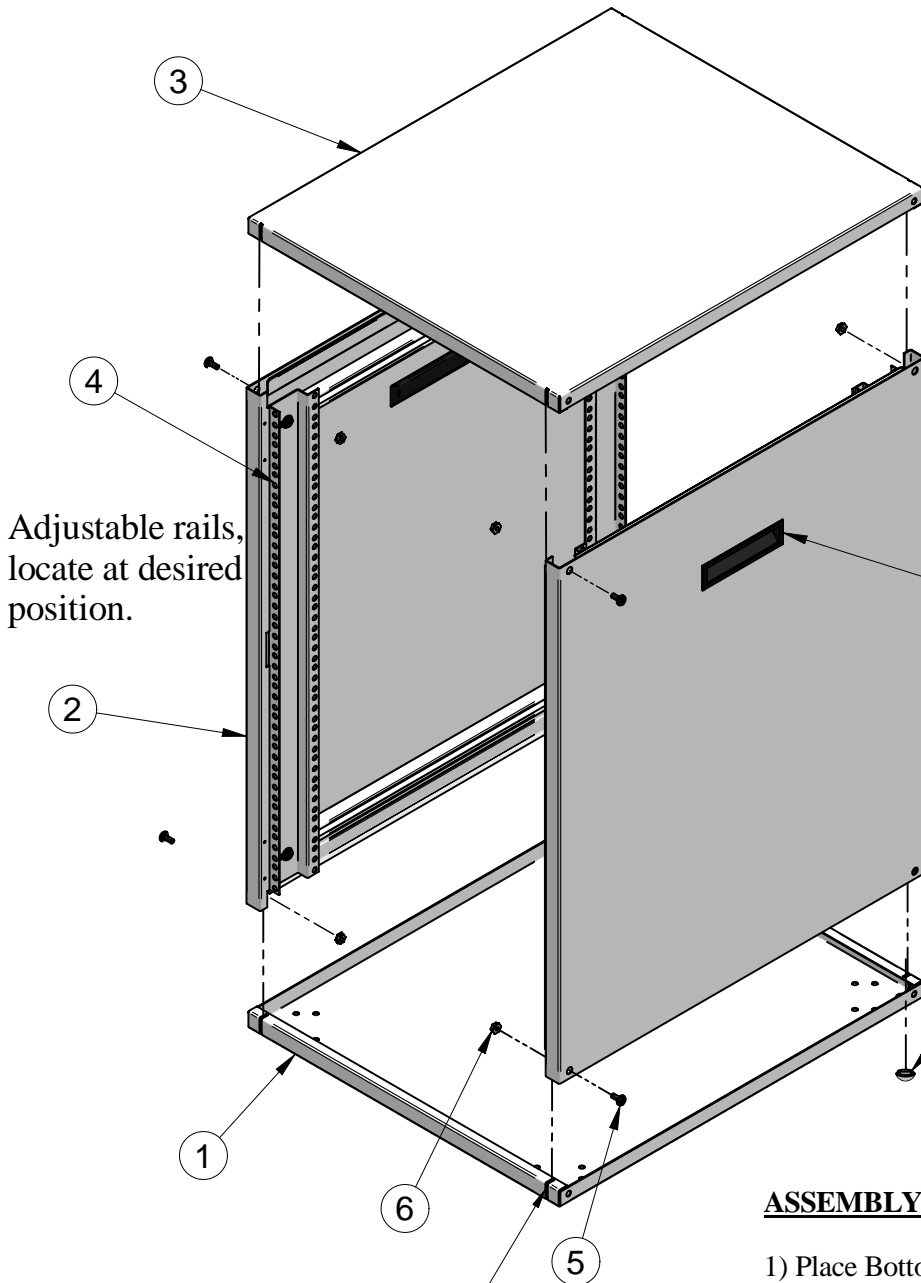

Adjustable rails, locate at desired position.

SLOTS, USE AS GUIDES FOR INSTALLING SIDES.

CLIP NUTS & RUBBER FEET ALSO INCLUDED.

NOTE: HANDLES MUST BE ON TOP HALF. ENSURE HANDLE IS INSTALLED PROPERLY SO THE CABINET CAN BE LIFTED UPWARDS.

RUBBER FEET

ASSEMBLY INSTRUCTIONS

- 1) Place Bottom (Item 1) on floor and install Sides (Item 2).
 - Use slots on Bottom as guides for inserting Sides.
- 2) Install Top (Item 3) in same fashion.
 - Ensure Top & Bottom is firmly in place and cabinet is square. (Tap lightly with rubber mallet to secure sides, if req'd)
- 3) Install 1/4-20 screws and nuts as shown (Items 5 & 6).
- 4) Install rubber feet (or casters, sold separately) in bottom if desired.
- 5) Locate adjustable rails at desired position.

TOOL BOX



Phillips Screw Driver



Slot Head Screw Driver



HAMMOND
MANUFACTURING™
ELECTRONICS GROUP

visit our website @ www.hammondmfg.com